

**BLOCK-1**  
**BLOCK-2**  
 ALL TIE BEAM MARKING AS TB.  
**TIE BEAM LAYOUT PLAN.**  
 SCALE=1:100

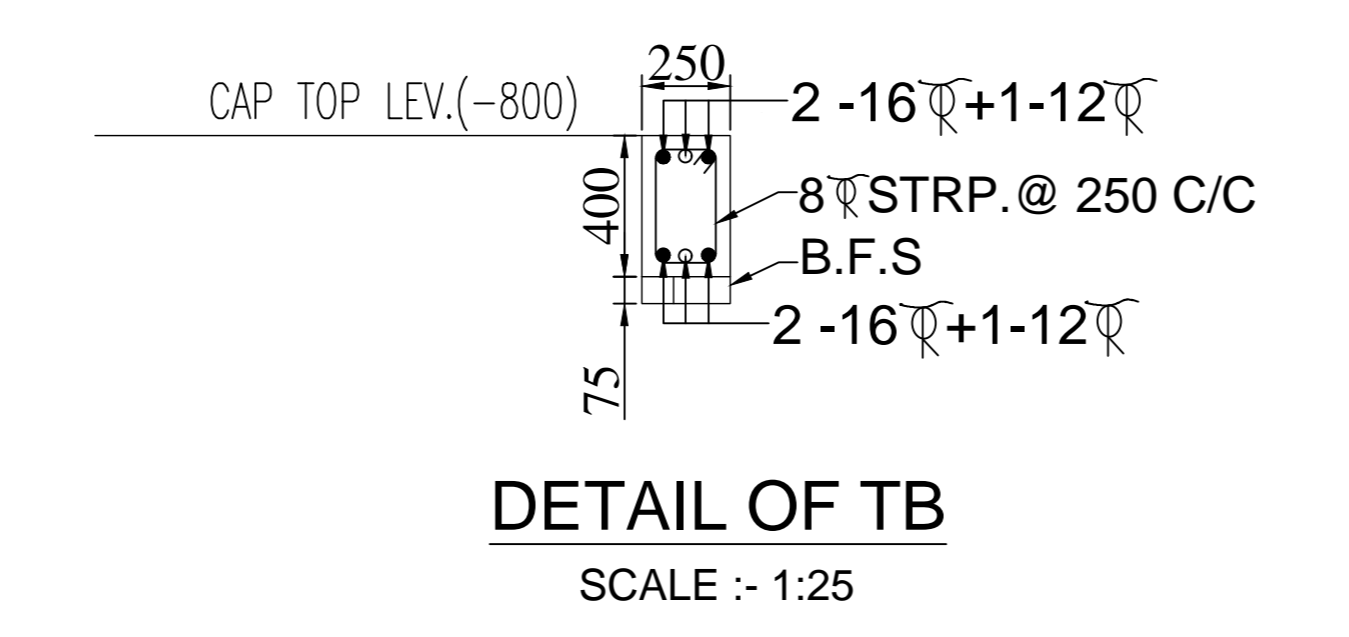
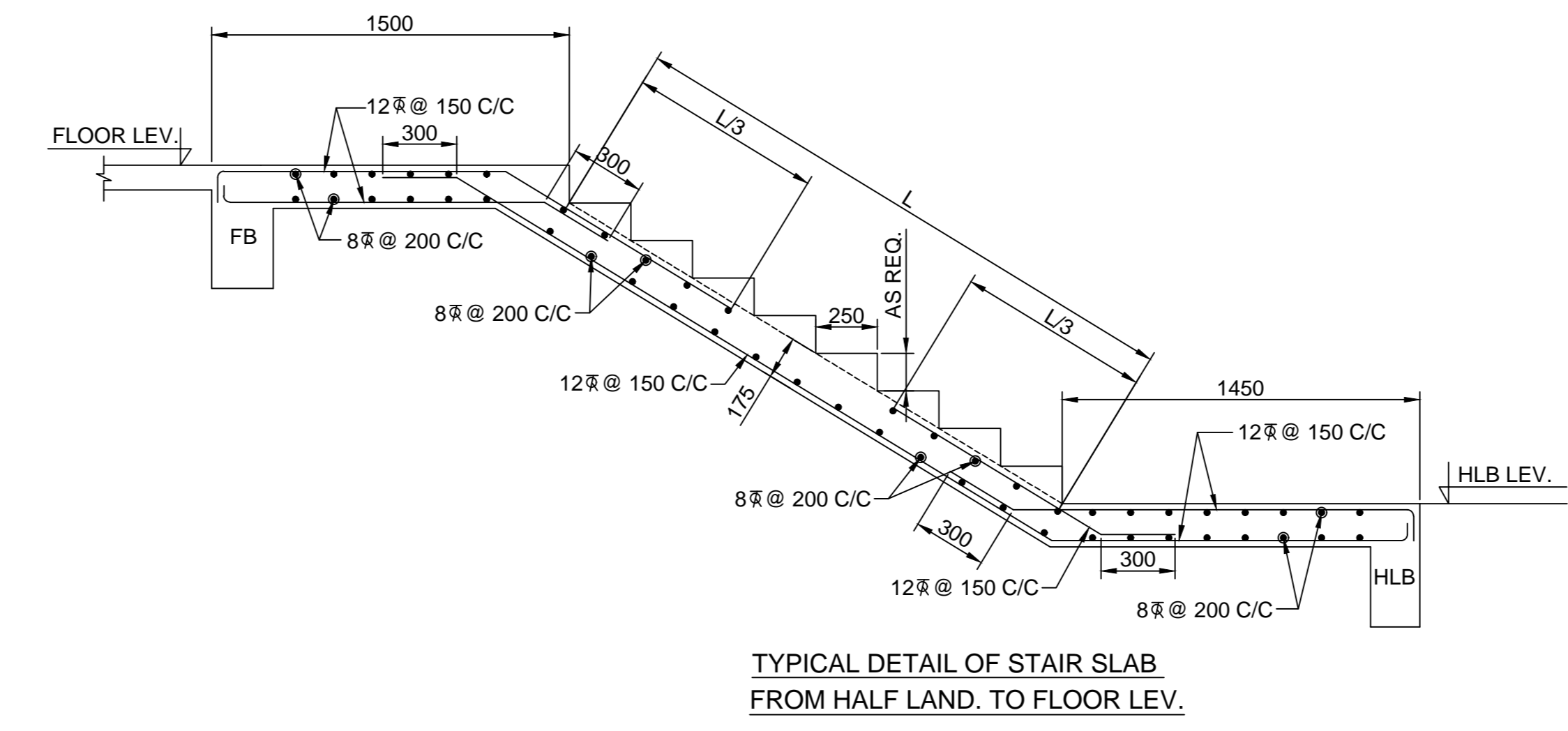

DESIGN IS BASED ON : AAC BLOCKS FOR MASONARY WALLS .

**CERTIFICATE OF OWNER**

1. I ENGAGE ARCHITECT AND E.S.E DURING CONSTRUCTION
2. I SHALL FOLLOW THE INSTRUCTIONS OF ARCHITECT OF THE BUILDING.
3. KAMARATI MUNICIPAL AUTHORITY WILL NOT BE RESPONSIBLE FOR THE STRUCTURAL STABILITY OF BUILDING AND ADJOINING BUILDINGS.
4. IF ANY SUBMITTED DOCUMENT IS FOUND TO BE FAKE OR FORGED, MUNICIPAL AUTHORITY MAY REVOKE THE SANCTION PLAN.
5. THE CONSTRUCTION OF WATER RESERVOIR EXECUTED UNDER THE GUIDANCE OF ARCHITECT & E.S.E

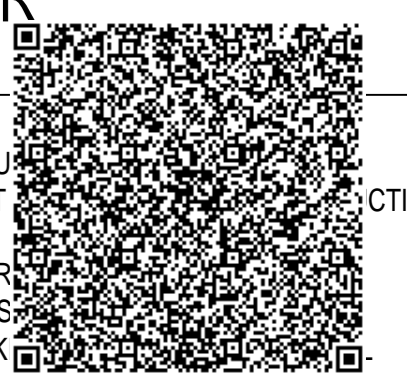

**RITZU GHOSAL**  
 SIGNATURE OF OWNER

CERTIFICATE OF STRUCTURAL STABILITY  
 WE HEREBY CERTIFY THAT THE FOUNDATION AND SUPERSTRUCTURE OF THE BUILDING PROPOSED FOR CONSTRUCTION ON PRE- 22 FEEDER ROAD, WARD NO.-10, HAVE BEEN SO DESIGNED BY ME/US WILL MAKE SUCH FOUNDATION AND SUPER STRUCTURE SAFE IN ALL RESPECT INCLUDING THE CONSIDERATION OF BEARING CAPACITY AND SETTLEMENT OF SOIL ETC.

**RAJ KUMAR AGARWAL**  
 COUNCIL REGISTRATION NO. CA/94/17940  
**SIGNATURE OF LBA**  
 (NAME ADDRESS AND EMPANELMENT NO.)  
 RAJ KUMAR AGRAWAL, ADDRESS.-8B,  
 ROYD STREET, KOL-16  
 COUNCIL NO.-CA/94/17940

**Kaushik Sengupta**  
 Structural Engineer I  
 LIC. REG. NO.-STRUCT-CLASS(I)-002  
**SIGNATURE OF STRUCTURAL ENGINEER**

**Rupak Kumar Banerjee**  
 Geo Technical Engineer I  
 LIC. REG. NO.-G.T/1/3  
**SIGNATURE OF GEO-TECHNICAL ENGINEER**

**Heleena Sengupta**  
 Structural Reviewer  
 LIC. REG. NO.-STRUCT-REV-002  
**SIGNATURE OF STRUCTURAL REVIEWER**

**ARCHITECT:-**  
**RAJ AGRAWAL & ASSOCIATES**  
 8B, ROYD STREET, 2ND FLOOR,  
 CALCUTTA - 16  
 PHONE :- 2566-3309 / 3293-3925 / 9674175675  
 email :- shripakr@gmail.com

**STRUCTURAL CONSULTANT**  
**ENGINEERS FORUM**  
 60/40/1 H.P. DUTTA LANE (GOLF GARDENS)  
 KOLKATA - 700033  
 PH. NO. - 3566-7944, 9874561607  
 email :- engg\_forum2005@yahoo.co.in

**PROJECT:-**  
 PROPOSED 6+11 (9+9) M. HT) STORED BUILDING AT PREMISES NO-22 FEEDER ROAD, KOLKATA 70007, ALSO COMMONLY KNOWN AS 22M FEEDER ROAD (HOLDING NO. 22) (FORMERLY HOLDING NO.22), WITHIN WARD NO. 10 OF THE KAMARATI MUNICIPALITY IN THE DISTRICT OF NORTH-24 PARAGANAS, LR. ENG NOS. S45, S46, S48, S49, S47, S43, S42, S41, S40, S46, S50, S41 RECORDED IN L.R. NOTAN NO. 1029, MOUDA, ARADHAN KAMARATI, J. L. NO. 1, POLICE STATION - BELURGOLA (FORMERLY BANANIGANGA)  
**TITLE :- STRUCTURAL SANCTION DRAWING.**  
 JOB NO. : 07/2023-2024  
 DRG. NO. : EF/S/02  
 DRAWN BY : PALASH  
 SCALE : 1:100, 1:25  
 DATE : 16.05.2024

**NOTES :-**

- 1) ALL DIAMETERS ARE IN MILLIMETERS.
- 2) GRADE OF CONC. : ALL DESIGN MIX  
 i. PILE :- M-25, WITH MINIMUM CEMENT CONTENT @ 400 Kg/CUM OF CONC.  
 ii. PILE CAP :- M-30.  
 iii. COLUMN & LIFT :- AS PER SCHEDULE.  
 iv. REST ALL :- M-30 UP TO 5TH. ROOF  
 M25 5TH. ROOF TO ROOF AND ABOVE.
- 3) P.C.C SHALL BE NOMINAL 1:1.5:3 (M20) AS PER IS: 456.
- 4) TOR STEEL REINFORCEMENT SHALL CONFORM TO LATEST IS: 1786 CODES WITH YIELD STRESS 550 MPa.
- 5) CLEAR COVER TO MAIN REINFORCEMENT SHALL BE AS FOLLOWS:-  
 a) PILE : 40 MM ALL SIDES FROM OUTERMOST MAIN BAR.  
 b) PILE CAP : 50 MM ALL SIDES FROM OUTERMOST MAIN BAR.  
 c) COLUMN : 40 MM ALL SIDES FROM OUTERMOST MAIN BAR.  
 d) TIE BEAM : 30 MM ALL SIDES FROM OUTERMOST MAIN BAR.  
 e) FLOOR BEAM : 30 MM ALL SIDES FROM OUTERMOST MAIN BAR.  
 f) SLAB : 20 MM ALL SIDES FROM OUTERMOST MAIN BAR.  
 g) WAIST SLAB : 20 MM ALL SIDES FROM OUTERMOST MAIN BAR.
- 6) MINIMUM LAP LENGTH :-  
 FOR PILE : 40 Ø WITH 3 SETS LAP WELDING IN BOTH SIDES FOR A LENGTH OF 25MM. FOR REST LAP LENGTH OF BARS TO BE PROVIDE AS KØ Ø DIA OF BAR.
- 7) MAXIMUM LOAD ON EACH PILE :-  
 FOR 500Ø 28 M. TIP PILES - 90 T.  
 FOR 500Ø 25 M. TIP PILES - 63 T.  
 FOR 500Ø 18.5 M. TIP PILES - 40 T.  
 AS PER THE SOIL INVESTIGATION REPORT PREPARED BY M/S JP GEO CONSULTANTS REP. BY JISHNU PAL.
- 8) POSITIONAL ECCENTRICITY OF ANY PILE MORE THAN, 50mm, FOR SINGLE PILE, AND 75 mm. FOR GROUP OF PILES SHALL NOT BE PERMITTED.
- 9) THE PILE HEADS SHALL PROJECT IN TO PILE CAP FOR 50 mm. THE HEADS TO BE NEATLY FORMED TO THE REQUIRED DIA.
- 10) ALL TIES TO BE SPOT WELDED WITH VERTICAL REINFORCEMENT.
- 11) BORING OF PILE :-  
 i. BORING SHOULD BE DONE WITH DMC METHOD AND BENTONITE SUSPENSION SHOULD BE USED (WITH SP.GR. 1.04 TO 1.2 gm/cm3 DURING DRILLING AS IS 2911 (PART-V/ SEC 2) CL A.3.1 IF DMC METHOD APPLIED.  
 ii. FOR PLACING OF CONCRETE IN PILE BORES, A FUNNEL SHOULD BE USED AND METHOD OF CONCRETING SHOULD BE SUCH THAT THE ENTIRE VOLUME OF THE PILE. SHAFT IS FILLED UP WITHOUT THE FORMATION OF VOIDS OR MIXING OF SOIL AND DRILLING FLUID WITHIN CONCRETE.
- 12) VERTICAL LOAD TESTING OF PILE SHOULD CONFORM IS-2911 (PART-4), IS-13620 & SP-16.
- 13) RCC BORED CAST IN SITU PILE SHOULD CONFIRM IS-2911 (PART-1, SEC-II)
- 14) EXT. TOP & BOTT.  
 FLOOR. BEAM- i) EXT. TOP TO BE PROVIDED AT L/4 FROM SUPPORT.  
 ii) EXT. BOTT. TO BE EXTENDED L/5 FROM SUPPORT.  
 SLAB - i) EXT. TOP TO BE PROVIDED IN ALL SUPPORTS FOR A LENGTH OF L/3 FROM SUPPORT.
- 15) ALL DRAWINGS SHALL BE CORRELATED WITH ARCHITECTURAL DRAWINGS & ANY DISCREPANCY SHALL BE BROUGHT TO NOTICE OF THE ENGINEER BEFORE EXECUTION.
- 16) THIS DRAWING TO BE READ ALONGWITH SPECIFICATIONS & ALL REFERENCE DRAWING.
- 17) ALL THE WORKS SHALL BE DONE AS PER RELEVANT IS CODE PERTAINING TO WORK.
- 18) CONTRACTOR MUST VERIFY ALL DIMENSION AT SITE BEFORE EXECUTION OF WORK NO CLAIM WILL BE ENTERTAINED. CONTRACTOR SHALL BE RESPONSIBLE TO PROPER LINE AND LEVEL OF STRUCTURE.
- 19) DESIGN IS BASED ON AS PER IS-456, IS-875, IS-1893, IS-2911, IS-13620 & SP-16.
- 20) STRUCTURAL DESIGN IS DONE FOR 'G+X' FOR ALL BLOCKS.
- 21) SEISMIC ZONE CONSIDERED FOR DESIGN AS ZONE-III & SMRF.

Type of Steel	Value of k for concrete mixes			
	M20	M25	M30	M40
Fe 500	57	49	45	40